

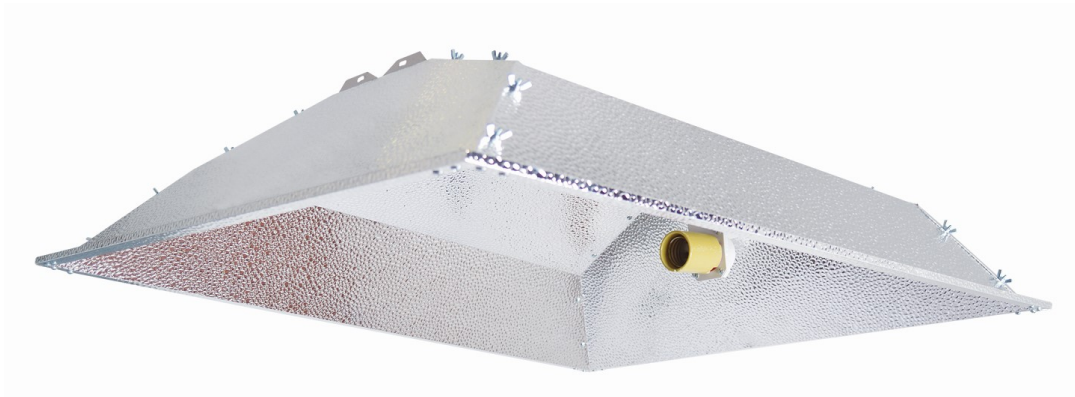

Instruction Manual

XXL Open Hood Reflector



Parts List

- 22–M4 wing nuts
- 38–M4*8 screws
- 2 –Side Aluminum sheet
- 2 –End Aluminum sheet
- 1 –Central Aluminum sheet
- 4 –Corner steel plates
- 1 –Support frame with socket kit
- 2 –V-hooks for hanging

Reflector Assembly

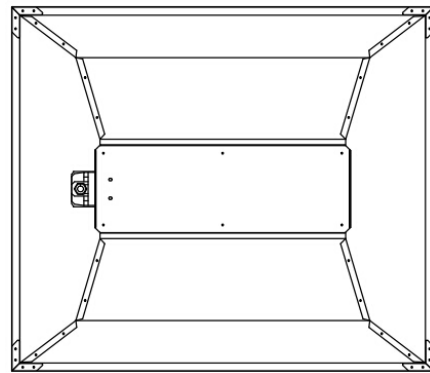
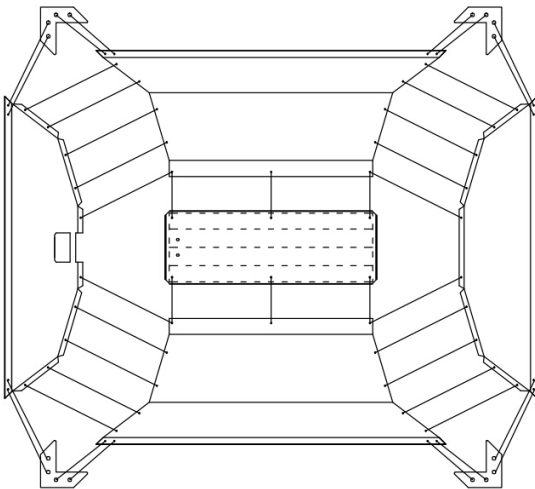

Final View

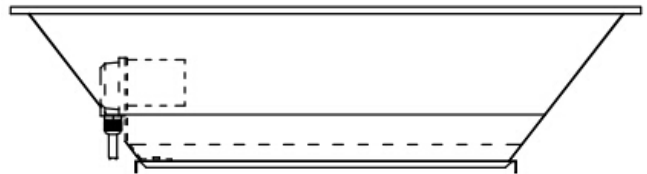
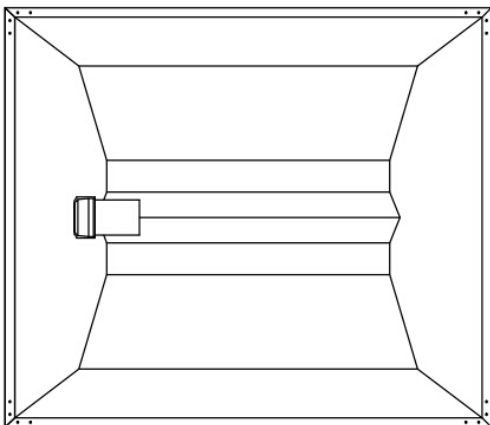

1 Year Limited Warranty Service

If the product will not work after you have read the troubleshooting guide and practiced the troubleshooting options, you are advised to return the Hydro Crunch™ light system to the retailer you purchased it from. The dealer will be able to examine the light and test its components. If they are not able to repair the light, they will return it to us for examination and repair/replacement. Do not attempt to repair any product on your own, as serious injury or death may result. If the retailer is not able to help you and the light is still under manufacturer's warranty, you may contact us for technical support. In some cases, you will be issued an RMA# (return merchandise authorization number) to return the unit for factory repair. Complete the warranty form below and return the light with all original packaging, your receipt of purchase, and a valid RMA# to the address below. Please pack and ship the light in its original packaging. If it is damaged in shipment we cannot be responsible and the warranty may be voided. Once we receive RMA package, it will be repaired or replaced and shipped back to you. Please note if an additional warranty was purchased and include the extended warranty sales receipt with your return.

RETURN FORM

Include the following if returning:

- ✓ Proof of purchase
- ✓ This completed form
- ✓ RMA# on the outside of the box
- ✓ Extended warranty receipt

Return Merchandise Authorization Number (Required): _____

Contact Name: _____

Address: _____

Phone #: _____

Email Address: _____

Please give a brief description of your technical issue: _____

SEND TO:

Hydro Crunch
17128 Colima Road Suite 510
Hacienda Heights, CA 91745
714-516-8176